



# FXG2 TORNADO GUN™

(PNs 66210, 66211)

## PRODUCT INSTRUCTIONS

PI-120



The FXG2 Tornado Gun™ is an air-actuated, dual-trigger waterblast control gun that is designed for maximum operator safety and field durability. The Tornado Gun utilizes a mandrel/seal configuration that can be easily overhauled in the field, as well as pushlock-type air-hose connections for ease of hose removal and/or replacement. The Tornado Gun is rated for 40,000 psi maximum operating pressure and utilizes a 9/16" Type M inlet connection.

Read these instructions thoroughly before installing, connecting, or using the FXG2 Tornado Gun. If any questions remain, call JETSTREAM at (800) 231-8192 or (832) 590-1300. Also read the yellow JETSTREAM SAFETY WARNING pamphlet included with the shipment of your new FXG2 Tornado Gun, and reproduced inside this publication. This product is sold with the understanding that the purchaser agrees to thoroughly train all operators and maintenance personnel in the correct and safe installation, operation and maintenance of the product and to provide adequate supervision of personnel at all times. Retain these instructions for future reference. If this product is resold or otherwise conveyed, purchaser must pass on the instructions to the new user.

# TABLE OF CONTENTS

Section 1: Safety ..... 3  
Section 2: Product Description .....12  
Section 3: Preparation for Use.....14  
Section 4: Setup.....16  
Section 5: Operation..... 17  
Section 6: Service ..... 20  
Section 7: Troubleshooting..... 29  
Appendix A..... 30  
Appendix B..... 32  
Appendix C..... 34  
Warranty ..... 36



## SECTION 1: SAFETY



Incorrect Use of High Pressure Waterblast  
Equipment May Cause Serious Injury  
Read these instructions in their entirety  
before using any JETSTREAM products.

This information was prepared to aid in the identification of potentially unsafe conditions when using high pressure waterblast equipment. It should be noted that other potential hazards may exist which might have not been mentioned in this brochure.

In all cases, JETSTREAM products are sold with the understanding that the purchaser agrees to thoroughly train all operating and maintenance personnel in the correct and safe installation, operation of maintenance of waterblast equipment and to provide adequate supervision of personnel at all times.

Read the following in its entirety before connecting, operating or repairing equipment. Purchasers and operators also should be familiar with the current version of the “Industry Best Practices for the Use of High Pressure Waterjetting Equipment” published by the Waterjet Technology Association, as well as any applicable OSHA regulations, standards and guidelines.

Should any questions arise concerning safe and proper procedure, contact JETSTREAM prior to the installation or use at (800) 231-8192 or (832) 590-1300.

# GENERAL WATERBLAST

1. Use only clear, clean water in high pressure system.
2. Place barricades with warning signs or barricade tape around work area.
3. Outfit all operators with Personal Protective Equipment (PPE). Hard hat with plastic face shield, rainsuit, non-skid knee boots **with metatarsal protection**, gloves, ear protection and body armor rated for operating pressures are considered minimum safety equipment. Proper respiratory protection is required where dangerous fumes or dust is present or created by the waterblasting operation. Follow applicable OSHA regulations, standards and guidelines regarding the use of respiratory protection if harmful fumes or dust is present during, or created by the waterblasting operation.
4. Use products intended for high pressure waterblasting only.
5. **No product should be altered** without written consent of the manufacturer.
6. **Read and follow all manufacturer's instructions** prior to using any waterblast product. Contact manufacturer.
7. Thoroughly review alternative methods before initiating any potentially dangerous waterblasting operation. Fully automated, semi-automated, and/or mechanized methods should all be considered first. Contact the applicable waterblasting manufacturers for assistance and recommendations.
8. The operator handling the cleaning device (with nozzle) must always have control of water pressure. A surface cleaning operator should operate a trigger style control gun capable of instantaneously stopping pressure to nozzle. A tube cleaning lance operator should operate a foot gun capable of instantaneously stopping pressure to the lance.
9. Inspect the condition of all components prior to use. Use no items which are in questionable condition.
10. Check the condition of thread connections prior to the make-up of any high pressure connection. Use Teflon tape and anti-seize on male pipe (NPT) thread for sealing purposes. Do not let tape overlap the male pipe thread end. Tape fragments may enter system water stream and clog nozzle's orifices.

**Do Not use a component with missing or damaged threads on the high pressure connections.**

**⚠ CAUTION** Use wrench flats (when available) or a properly adjusted smooth jaw plier wrench (JS PN 64119) for tightening components. Avoid using pipe wrench as wrench marks will cause high pressure components to crack and fail.

11. All high pressure hose connections require a hose restraint (whip check), including connection at fluid end discharge.
12. Before attaching a nozzle to the control gun or tube cleaning lance, **operate the pump at low speed to purge** dirt and debris from system. **Dirt and debris can clog nozzle orifice(s) and cause excessive system pressure which could lead to a lance failure.**
13. With nozzle installed, **operate the pump at a low speed (low pressure) for test.** Should system repairs or adjustments be necessary, stop pump and relieve all pressure before making required repairs or adjustments. The pump operator should watch the nozzle operator at all times in case any difficulty arises and it becomes necessary to depressurize system. If the pump operator does not have a clear line of sight to the nozzle operator, it may be necessary to have another employee available to communicate between the nozzle and pump operators.
14. With the system operating properly, **increase pump speed slowly until operating pressure is reached** and adjusted. Pressure adjustments should always be made slowly. The nozzle operator shall be warned before any pressure adjustment is made by the pump operator. A sudden change in reaction force may cause the nozzle operator to lose balance.
15. Use **minimum pressure required** for cleaning. Do not exceed the operating pressure of the system's lowest pressure-rated component. All equipment pressure rating markers and warning tags should be left intact.
16. Waterblast operators must be made aware that the **cleaning nozzle's discharge jets(s) can inflict serious body wounds.** Supervisors should demonstrate the potential danger of discharge jet(s) by showing all new operators the effect of a waterjet by cutting a scrap piece of wood such as a 2" x 4".
17. If equipment malfunctions or a system malfunction is suspected, immediately stop cleaning activity and relieve the pressure in the system before attempting any repairs. Always follow the manufacturer's repair instructions.

18. Only trained persons should be authorized to perform any maintenance or repair.

19. Following any repairs, the system should be operated at low pressure for test. Bring equipment up to operating pressure slowly.

20. For shutdown in freezing conditions, even for brief periods, drain water from all components. Prior to starting operations in freezing conditions, the operation of all equipment components must be checked carefully to make sure components are not frozen and can be operated.

21. Store components properly by protecting them from damage when not in use. Be sure all safety warning tags and markers remain intact.

## **CONTROL GUNS AND DEVICES**

1. **Read General Safety** section before connecting or using control guns or control devices.

2. Thoroughly review alternative methods before initiating any potentially dangerous shotgunning or hand lancing operation. Fully automated, semi-automated, and/or mechanized methods should all be considered first. Contact the applicable waterblasting manufacturers for assistance and recommendations.

**⚠ WARNING** As described in the Industry Best Practices for the Use of High Pressure Waterblasting Equipment published by the Waterjet Technology Association, the standard shotgun barrel length shall be a minimum length of 48” to minimize the risk of nozzle discharge accidentally striking the operator’s feet, legs, or body. See Section 11.10.6. The WJTA has recognized that deviations or variances from these best practices may be acceptable under certain circumstances. See Section 2.7. If users believe deviation from this 48” standard is acceptable, they should follow procedures outlined in Section 2.7 to minimize risk to the operator. Among other things, users should ensure that other measures to perform the work have been considered and exhausted, senior safety management and customers have considered and approved the deviation, operators have been properly trained and warned about any increased risk associated with the deviation, and operators are wearing all appropriate PPE, including body armor rated for the operating pressure.

3. Prior to use, thoroughly check control gun or control device for smooth and proper operation. Control guns and control devices should also be checked for proper operation before each operating shift. Do not use any control gun or control device that has not been checked before your operating shift.
4. A control gun operator using a hand-held gun should position and brace his body for the gun's rearward reaction force before depressing gun trigger. Gun's rearward reaction should be a maximum force of 40 to 50 lbs. (or 1/3 body weight of operator.) The control gun operator should maintain firm, solid footing to counter gun's rearward reaction.
5. The use of a Safety Shroud and a Safety Whip Hose with handheld control guns is strongly recommended for additional operator protection against a burst occurring in the high pressure hose connected to the gun. Use of Hand Grip and Shoulder Stock in hand-held control guns will provide greater operator comfort and safety.
6. Fall protection should be provided when blasting on scaffolding or sloping surface per OSHA guidelines. Do not operate a hand-held gun while standing on slippery surfaces.
7. The control gun operator should always start blasting with a low system pressure and slowly increase blasting pressure. Depress and release control gun trigger/pedal several times at operating pressure to check the control gun's operation before starting cleaning operations.
8. A dump type control gun should always open fully and reduce the system pressure to near zero immediately when its trigger/pedal is released. If this type of control gun does not relieve system pressure immediately or system pressure does not fall below 200 psi when trigger/pedal is released, do not use the control gun.
9. The control gun operator should never pass a control gun to another operator without first stopping the pump and water flow to the control gun. Passing off a control gun without first stopping system waterflow is dangerous because of possible accidental trigger actuation.
10. Do not use a control gun or control device that has malfunctioned or you suspect malfunctioned without having it repaired and/or thoroughly checked for proper operation by a qualified high pressure maintenance mechanic or your supervisor.
11. Do not use a control gun that does not have a trigger guard.
12. Never tie, wedge or clamp a control gun's trigger in the closed position.

13. All electric throttle control cords should be rated for wet conditions. All cord connections and switches should be kept out of water.
14. Any hose used for transporting dump water back to pump should have a large enough diameter and short enough length so that potentially dangerous back pressure is kept low. Protect hose from traffic.
15. Hand-operated control guns should never be used as foot-operated devices.

## **PRESSURE RELIEF DEVICES**

1. **Read General Safety** section prior to installing Relief Valve and/or Pressure Relief Devices.
2. A waterblast system should include both primary and secondary pressure relief protection:
  - A. For primary protection a primary rupture disc assembly or spring-loaded relief set at 1.2 times, maximum operating pressure is recommended (i.e. relief valve is set at 12,000 psi if maximum operating pressure is 10,000 psi)
  - B. For secondary protection a rupture disc assembly containing a manufacturer's approved disc having a burst rating of 1.4 times maximum operating pressure is recommended.
-  **WARNING** Only use a rupture disc holder which will NOT permit the use of coins or other objects in place of discs.
3. Relief devices should never be mounted so the discharge could strike personnel.
4. Never install a shut-off valve between the pump and relief device.
5. "Set pressure" must be prominently displayed on all relief devices. Never install or use a relief device unless its "set pressure" is known.
6. Do not attempt to correct a leaking relief valve by increasing spring tension as this will increase its set pressure.
7. Do not use a pressure relief valve as a combination relief and throttling device.
8. Keep relief valve dry during freezing conditions.

**NOTE:** Pressure relief devices are imperative for the protection of both operator and equipment from dangerous over-pressurization.

## HIGH PRESSURE HOSE

1. **Read General Safety** section prior to connecting high pressure hose.
2. Do not use a high pressure hose with a burst rating less than 2.5 times the pressure at which it will operate. 10,000 psi operating pressure high pressure must have a minimum 25,000 psi burst rating. 8,000 psi operating hose must have a minimum 22,000 psi burst rating.
3. Do not use a high pressure hose that has an unknown burst rating or manufacturer's operating pressure rating.
4. Use of a Safety Shroud is strongly recommended for added safety where hose connects to control gun.
5. Use of hose restraint (whip check) is required at all hose connections, including connections at fluid end.
6. Always apply wrench to wrench flats when making threaded connections. Do not apply wrench on the end fitting ferrule (collar).
7. **Remove hose from service if:**
  - A. Cover is damaged and reinforcing wires are exposed to rust and corrosion;
  - B. Cover is loose, has blisters or bulges;
  - C. Hose has been crushed or kinked;
  - D. End fitting shows evidence of damage, slippage, or leakage.
  - E. Hose has been exposed to pressures greater than 50% of burst rating; or
  - F. Hose is three or more years old, regardless of condition.
8. Disconnect, drain, coil and store hose properly after use.
9. Never attempt to repair or recouple high pressure hoses in field. High pressure hose end fittings are the permanently crimped type and can only be properly installed with hydraulic crimping equipment.

## NOZZLES

1. **Read General Safety** section.
2. Nozzle flow ratings must be compatible with pump discharge and pump pressure rating. (See Nozzle Flow Rating Chart on page 34.)
3. Use only nozzles with a manufacturer's pressure rating of at least the operating pressure or a burst rating or no less than 3.0 times the

desired operating pressure.

4. Prior to installation, make sure the nozzle has no clogged orifices.
5. Apply 3 - 4 wraps of Teflon tape to male connection threads on the nozzle. Apply anti-seize compound over the sealant tape for additional protection against galling in connection threads. Wrench connection 1 1/2 - 2 turns past hand tight. A minimal thread engagement of four (4) threads should exist on all Jetstream NPT pipe connections.
6. **⚠ CAUTION** Use wrench flats (when available) or a properly adjusted smooth jaw plier wrench (JS PN 64119) to tighten nozzle. Avoid using pipe wrench as wrench marks will cause nozzles to crack and fail.
7. Blocked orifice(s) can cause excessive system pressure and failure. If orifice(s) appear clogged or partially blocked with dirt or debris, remove nozzle from J-Force and clean immediately.

**8. Remove nozzle from service if:**

- A. Nozzle is split or damaged;
- B. Nozzle sidewall is worn by more than 25% at any point;
- C. Nozzle's ability to hold pressure is questionable
- D. Threads are missing or damaged

## **HIGH PRESSURE FITTINGS**

1. **Read General Safety** section prior to installing fittings in system.
2. Use non-brass or non-cast iron fittings which are made for high pressure waterblast use.
3. Use only high pressure fittings which are clearly marked with the operating pressure.
4. High pressure fittings should have a known burst rating of not less than 3.0 times system operating pressure. Never use a damaged or corroded fitting or one with damaged or missing threads.
5. Use only high pressure rated fittings and hose in the waterblast system. For 10,000 psi waterblast service all fittings and hose should have a minimum burst rating of 25,000 psi; for 15,000 psi service they should have a minimum burst rating of 37,500 psi; for 20,000 psi service they should have a minimum burst rating of 50,000 psi.
6. Use wrench flats (when available) or a properly adjusted smooth jaw plier wrench (JS PN 64119) to tighten fittings. Avoid using pipe wrench as wrench marks will cause high pressure fittings to crack and fail.

## REPLACEMENT PARTS

1. Read **General Safety** section prior to repairing equipment and installing replacement parts.
2. Only trained persons should be authorized to perform maintenance or repairs to equipment.
3. Read and follow all manufacturer's repair instructions. All tool, torque, clearance and lubrication recommendations should be followed.
4. During replacement of any part, inspect mating part for wear and replace if necessary.
5. Do not attempt to install or use a part whose dimensions, clearances, function or use are suspect.
6. Test repaired equipment carefully and thoroughly before putting it into service. Do not put any piece of repaired equipment into service if its performance is questionable. If repaired equipment performance is questionable, call manufacturer of repair parts for assistance.

This section concludes all the same information included in the yellow JETSTREAM SAFETY WARNING pamphlet (PI-082).

## SECTION 2: PRODUCT DESCRIPTION

The FXG2 Tornado Gun™ is an air-actuated, dual-trigger waterblast control gun that is designed for maximum operator safety and field durability. When used in conjunction with the 40K Remote Control Valve, the operator is able to build pressure in the system only when both gun triggers are squeezed simultaneously. When both of the gun triggers are squeezed, air from the control valve flows to the gun to rotate the barrel and front nozzle head; an air signal from the gun is then sent back to the 40K Remote Control Valve to close the control valve, which allows high pressure water to flow to the gun. When either of the gun triggers are released, the 40K Remote Control Valve “dumps”, or relieves, the high-pressure water to atmospheric pressure. (See PI-121, 40K Multi-Mode Valve, for complete instructions.)

The Tornado Gun utilizes a mandrel/seal configuration that can be easily overhauled in the field. Refer to the chart on page 21 for the replacement seal for the Tornado Gun.

The Tornado Gun is rated for 40,000 psi maximum operating pressure and utilizes a 9/16” Type M male inlet connection. The Tornado Gun also utilizes 1/4” pushlock-type air-hose connections for ease of hose removal and/or replacement.

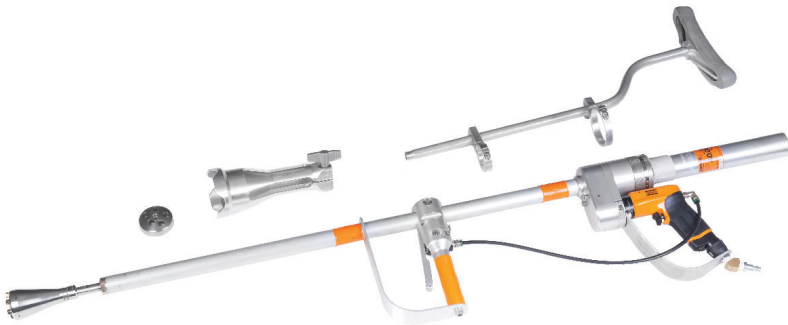

# Product Specifications

Model Name	FXG2 Tornado Gun 36" Barrel (PN 66211)	FXG2 Tornado Gun 48" Barrel (PN 66210)
Maximum Operating Pressure (psi)	44,000	
Minimum Operating Pressure (psi)	10,000	
Maximum Flow (gpm)	6	
Maximum Operating Pressure (bar)	3,034	
Minimum Operating Pressure (bar)	689	
Maximum Flow (l/min)	26	
Inlet Connection	9/16" Type M male	
Speed Range (rpm)	2000 - 2500	1500-2000
Nozzle Types Accepted	UHPX, UHPXi, UHPXD	
Length (in)	52	63
Weight (lbs)	13.0	13.8
Length (mm)	1320	1600
Weight (kg)	5.9	6.3

## SECTION 3: PREPARATION FOR USE

### 3.0 BEFORE PUTTING TORNADO GUN INTO SERVICE

#### NEW TORNADO GUN

3.1 Check the gun carefully upon removal from its shipping container for damage. DO NOT assemble or use the gun if any damage is apparent or the condition of any component is questionable.

3.2 New Tornado Guns are shipped completely assembled and ready to be put into service. Adjust the front trigger/handgrip by loosening the wing nut located at the top of the handle and moving and/or rotating the trigger/handgrip to a desirable location and then re-tightening the wing nut.

**⚠ WARNING** Both triggers/handgrips must always be used on gun to maintain safe control and proper operation. Do not use a Tornado Gun that has missing, modified, or broken triggers/handgrips. Loss of control of the gun could result in severe injury or death.

3.3 Check the gun's trigger operation. Both triggers should move smoothly and return positively to the trigger's fully open position when released. If the trigger action is not smooth and positive, determine and correct the cause before putting the gun into service.

Front handle plumbing should be confirmed as shown in the image below. The lower connection is labeled AIR IN and this line comes from the air drill. The upper connection is labeled as AIR OUT and this line goes to MMV signal valve.

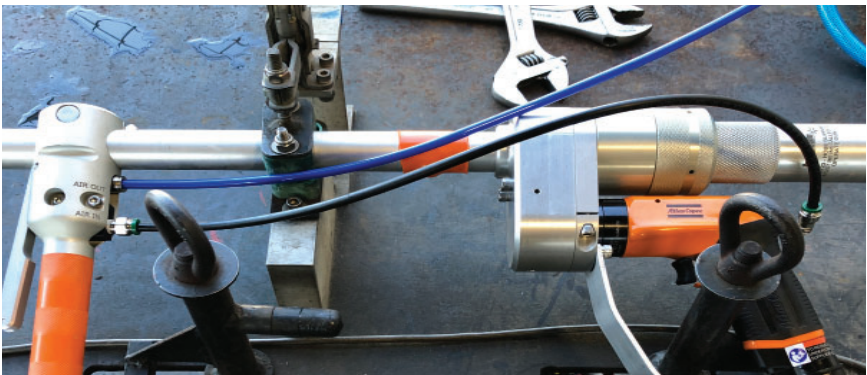

3.4 The FXG2 Tornado Gun must be inspected in conjunction with the 40K Remote Control Valve. With the nozzles removed from the nozzle head, the system water should be turned on and both triggers of the Tornado Gun should be squeezed and released. The 40K Remote Control Valve should be checked for air leaks, and checked to make sure that the Control Valve opens and closes correctly. If the Control Valve or the FXG2 Tornado Gun is not operating correctly, determine and correct the cause before putting the FXG2 Tornado Gun into service.

## **PREVIOUSLY USED TORNADO GUN**

**⚠ IMPORTANT** Do not use a Tornado Gun that has not had the following procedures and inspection previously performed on it.

The following cleaning and inspections must be performed on the gun before the start of each working shift:

3.5 Inspect all components. The air and water hoses should be secure and free of cracks, splits, or holes. Both triggers should move smoothly and return positively to the trigger's fully open position when released. If the trigger action is not smooth and positive, determine and correct the cause before putting the gun into service.

3.6 Inlet connection fitting and nozzle should be tight and in good condition. The hose support burst shield must be installed at the rear of the gun at the water inlet connection.

3.7 Check the 40K Remote Control Valve's operation in conjunction with the Jetstream Tornado Gun. With the nozzles removed from the nozzle head, the system water should be turned on and both triggers of the Tornado Gun should be squeezed and released to confirm that water is exiting the nozzle head and is being controlled by the valve. The 40K Remote Control Valve should be checked for air leaks and checked to make sure that the dump valve opens and closes correctly. If the Control Valve is not operating correctly, determine and correct the cause before putting the 40K Remote Control Valve into service.

## SECTION 4: SETUP

### 4.0 CONNECTING TORNADO GUN

4.1 Use only 40,000 psi rated fittings and hose for connecting the gun. They should have a minimum burst rating of 100,000 psi.

4.2 Use of a 6' safety whip hose is recommended. Safety whip hoses can be replaced frequently for high operator safety.

4.3 Before tightening up cone and seat type connections, first clean and inspect, apply antiseize compound to all threads, cone, and seat areas for protection against galling.

**⚠ WARNING** A multi-mode control valve must be used with each gun when 2 or more waterblast operators are connected to a single waterblast unit. Each waterblast operator must have independent control of nozzle pressure at their location.

4.4 Before installing the blast nozzle, check the nozzle size to make sure its orifice(s) is not too small in order to prevent overpressurization when the waterblast system is pressurized.

4.5 For operator safety, all high pressure hose sections connected to the gun and Remote Control Valve should be in good condition and free of leaks, kinks, and cover damage. The hose support burst shield must be installed.

4.6 Always purge the hose string between the pump and the gun of dirt and debris by pumping water through the hose with the waterblast pump prior to connecting the hose to the gun.

**⚠ DANGER** Do not shorten gun barrels or use a Tornado Gun with a working distance (primary air motor trigger to nozzle tip) of less than 40". Severe injury or death may result.

## SECTION 5: OPERATION

**⚠ WARNING** Never tie or wedge the gun triggers in their closed position or tap into the control valve's air cylinder directly. This renders the dump mode useless as a safety if the operator slips or otherwise loses control of the gun and needs to relieve the system's pressure by releasing the triggers.

5.1 Do not connect multiple dump type control guns together to a single high-pressure water source without the use of a multi-mode control valve for each gun to make each gun operator independent of the other operators. Call Jetstream for assistance if two or more Tornado Guns must be used in the waterblast system.

5.2 Make sure that the oil flow through the Multi-Mode Valve from the oiler is set correctly. To set the oiler, close off the flow control knob by turning it clockwise, then turn the adjustment knob counter-clockwise approximately 2 turns (or visually confirm 1-2 drops every 5 seconds while blasting). See PI-121, 40K Multi-Mode Valve.

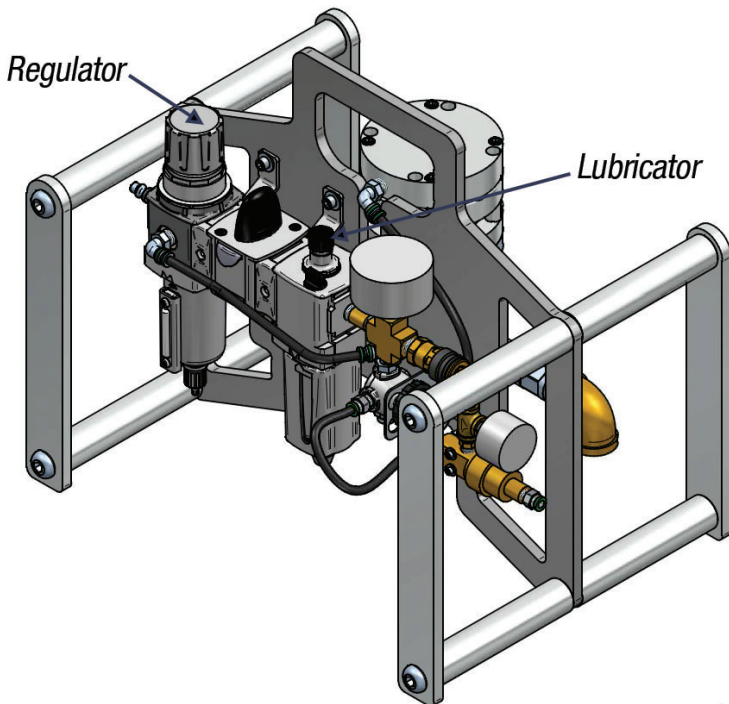

5.3 Make sure that the air regulator is set correctly. The pressure should be set for no lower than 80 psi and no higher than 120 psi while the gun is in operation (not at rest). To set the proper air pressure, pull up on the air regulator adjustment knob and turn clockwise for more air pressure and counter-clockwise for less air pressure. Once the air pressure is set, push down on the adjustment knob until it “clicks” and locks. See PI-121, 40K Multi-Mode Valve.

5.4 Check the Remote Control Valve for smooth and proper operation. DO NOT use the Remote Control Valve if it has not been cleaned and inspected before the start of the working shift. See PI-121, 40K Multi-Mode Valve.

5.5 Never operate the Tornado Gun if the Remote Control Valve does not fully open and reduce the system pressure to near zero immediately when its triggers are released. The control valve must relieve the water pressure immediately to below 200 psi when the trigger/pedal is released.

5.6 Be sure the retaining nut is seated against the housing shoulder before operating (see WARNING on page 24). Attempting to run at pressure with the nut backed off the shoulder will result in catastrophic seal failure.

5.7 Never operate the Tornado Gun without the hose support burst shield. This supports the high pressure hose, acting as a strain relief while providing coverage protection in case of a hose or fitting leak.

#### PROPER WATERBLAST TECHNIQUE

5.8 The gun operator must maintain firm solid footing to counter the gun's blasting reaction. This rearward reaction is usually 40 to 60 pounds of force, depending on nozzle selection, pressure, and flow. Use fall protection when blasting on scaffolding or sloping surfaces. DO NOT operate the gun while standing on slippery surfaces.

5.9 Check high pressure seal condition at start of shift and after every 2 hours of operation by pointing nozzles safely away from any target and pulling both triggers. Operate the gun in this manner at 15,000 - 20,000 psi and at 40,000 psi while viewing the weep holes in the swivel nut directly above the air drill. Any drips or leaks indicate a worn HP seal and require seal replacement. Do not blast with a leaking HP seal as this will allow hot water to drip onto operator's hands and cause water to flush grease from the swivel bearings and damage the swivel shaft.

5.10 Make sure that no water is flowing out of the dump port of the Remote Control Valve while blasting. The air pressure while blasting must be greater than 80 psi and less than 120 psi.

# SECTION 6: SERVICE

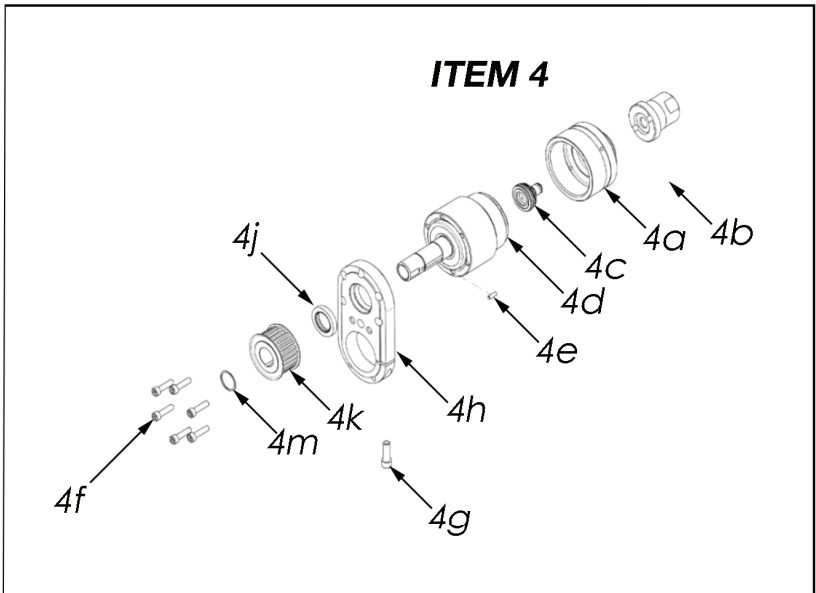
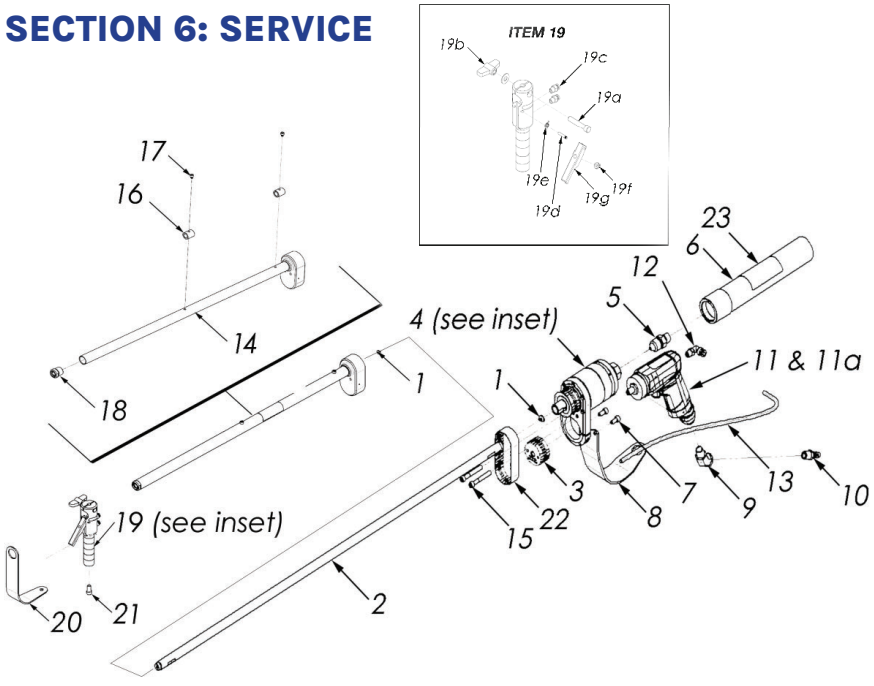

Figure A

Assembly PNs 66210, 66211							
Item	Qty	Part Number	Description	Item	Qty	Part Number	Description
1	2	54059	Button Seal	11a	1	66848	Drill Service Kit
2	1	53701	36" Barrel	12	1	27733	Elbow
		53894	48" Barrel	13	1	27740	Tubing
3	1	54307	Driver Sprocket	14	1	53790	36" Barrel Housing
4	1	66023	Swivel Assy			53895	48" Barrel Housing
4a	1	64123	Swivel Nut	15	2	27717	Capscrew
4b	1	53709	Inlet Adapter	16	1	53771	Center Barrel Bushing
4c	1	66021	Seal Kit	17	1	67325	Capscrew
4d	1	66022	Swivel Rebuild Kit	18	1	53972 (with seal)	Front Barrel Bushing
4e	1	27277	Pin	18a	1	27707	Barrel Seal
4f	6	27716	Capscrew	18b	1	53732	Front Barrel Bushing
4g	1	27713	Capscrew	19	1	67330	Secondary Handle
4h	1	53703	Mounting Plate	19a	1	53762	Clamp Stud
4j	1	27708	Shaft Seal	19b	1	64451	Nut
4k	1	53782	Driven Sprocket	19c	2	61678	Tubing Adapter
4m	1	27712	Retaining Ring	19d	1	53787	Pin
5	1	27530	Connector M9 x .38	19e	1	53798	Spring
6	1	53723	Hose Support	19f	1	61676	Valve
7	2	25261	Capscrew	19g	1	61670	Trigger
8	1	29808	Trigger Guard	20	1	27662	Trigger Guard
9	1	28224	Elbow	21	1	27714	Capscrew
10	1	28223	Male QD Fitting	22	1	27661	Belt
11	1	65098	Pneumatic Drill	23	2	64268	Label, VSS

**NOTE:** Part numbers and descriptions are subject to change without notice.

## 6.0 FXG2 TORNADO GUN MAINTENANCE

### 6.1 REPLACING THE HIGH PRESSURE SEAL

If water begins to leak from weep holes at rear of gun during operation, replace high pressure seal as follows:

1. Remove hose support burst shield (6) and disconnect high pressure hose.



2. Loosen and remove retaining nut at back of swivel (4a).



3. Remove seal adapter (4b) by pulling back away from gun. Push out worn seal from adapter ID using blunt object. Be careful not to damage seal adapter.



4. Clean all dirt and debris from rotary swivel body and check condition of the swivel shaft. Install new bushing (PN 67541) over swivel shaft, large diameter first.



5. Install seal (PN 53707) onto shaft cone-end first. O-ring should face away from gun as shown.



6. Push seal adapter over seal until face bottoms on swivel body. Install and tighten retaining nut.

**⚠ WARNING** Be sure the retaining nut is seated against the housing shoulder before operating. Attempting to run at pressure with the nut backed off the shoulder will result in catastrophic seal failure.



7. Connect supply hose to back of seal adapter and re-install hose support burst shield. Do not operate without hose support burst shield.
8. The gun should now be ready to use. Increase pressure slowly until desired blast pressure is reached.

## 6.2 REPLACING THE DRIVE BELT

If barrel stops rotating, or rotates erratically, the drive belt may be damaged. Inspect and replace belt as follows:

1. Remove signal hose from secondary control handle by pushing in on ring while pulling hose.
2. Remove nozzle head.
3. Using a 3/16" allen wrench, remove the two housing retainer screws (15) and slide barrel extension/housing assembly off of front barrel. Inspect drive belt for damage.
4. If damaged, replace belt (22) by removing driver timing pulley (3). Using a 1" spanner wrench (PN 63789) and 3/16" hex wrench, remove the driver pulley from the air drill shaft.
5. Remove driver pulley and belt and install new belt over barrel and driver pulley.
6. Replace driver pulley onto air drill.
7. Increase pressure slowly until desired blast pressure is reached. Front barrel should rotate at approximately 2000-2500 RPM at 90 psi supply air pressure (1500-2000 RPM for 48" gun).

## 6.3 REPLACING THE MAIN BEARING

If barrel stops rotating, or rotates erratically, the main bearing may also be damaged. Inspect and replace bearings as follow:

1. Complete steps 1 - 5 of previous section 6.2.
2. Remove front barrel.
3. Using a small pick or screwdriver, remove the spiral retainer ring (4m) from the swivel shaft.
4. Slide driven pulley (4k) and key (4e) from shaft.
5. Using a 5/32" allen wrench, remove the six swivel body capscrews (4f).
6. Separate the body from mounting plate (4h).

7. Pull shaft/bearing assembly from body using four jacking setscrews and inspect shaft and/or bearings for damage or improper operation.

8. To replace bearings, press bearings off shaft using an arbor press. Press new bearings onto shaft using arbor press with Jetstream spacers. Make sure bearing orientation is correct (see image). Note that wide outer race with markings on both bearings will face outward away from each other.

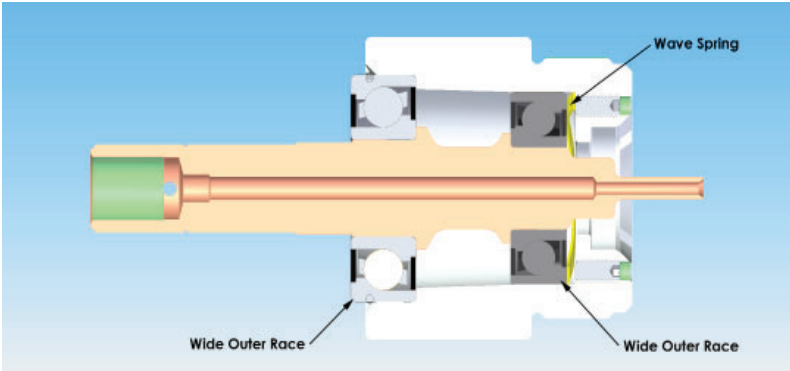



9. Replace lip seals in mounting plate if necessary.
  10. Re-assemble shaft/bearing assembly into body and install to mounting plate using the six 10-32 capscrews. Torque capscrews to 60 In-Lbs.
  11. Assemble the remainder of gun in reverse of disassembly.
  12. Begin blasting at low pressure while observing nozzle rotation. Front barrel should rotate at approximately 2000-2500 RPM at 90 psi supply air pressure (1500-2000 RPM for 48" gun).
  13. Increase pressure slowly until desired blast pressure is reached.
- 6.4 REPLACEMENT SEAL KIT IDENTIFICATION

**⚠ WARNING** Use only the correct seal kit to repair your control gun. Failure to use the correct pressure-rated seal kit could result in seal failure and possible control gun damage and operator injury.

See YouTube for videos showing the FXG2 Tornado Gun.

 **YouTube** <https://www.youtube.com/user/JetstreamWaterblast>



## SECTION 7: TROUBLESHOOTING

### 7.0 FXG2 TORNADO GUN TROUBLESHOOTING

<b>Problem</b>	<b>Possible Cause</b>	<b>Remedy</b>
Barrel won't spin/ spins too slow	Air pressure too low	Increase pressure to $\geq$ 90 psi
	Air volume insufficient	Increase volume to $\geq$ 20 cfm
	Air drill internals damaged/corroded from water in air	Replace worn part
	Leaks in air lines	Repair leaks
	Belt damaged	Replace belt
	HP seal bushing galled on swivel shaft	Return for service or polish shaft and replace HP seal and bushing
	Swivel bearings damaged	Replace bearings
	Barrel bushings worn	Replace bushings
	Barrel bent	Replace barrel
Gun gets warm	Leaking HP seal	Replace seal
	Supply water too hot	Use cooler water
Water leaks	Bad connection at nozzle head or swivel shaft	Tighten or replace button seal
	Weep hole leak	Replace HP seal
Barrel vibrates	Barrel bent	Straighten or replace
	Bushings worn	Replace bushings
	Nozzles worn	Relace nozzles

# APPENDIX A

## Exploded Views

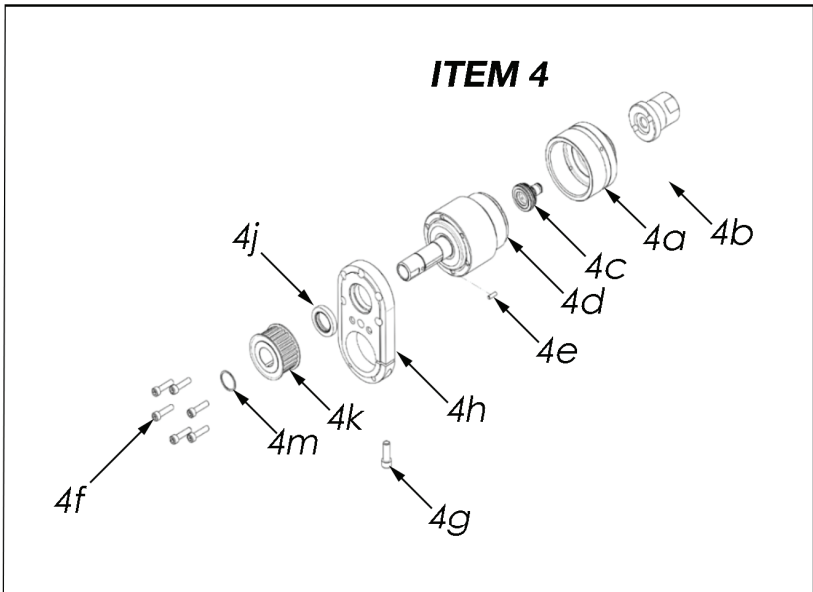
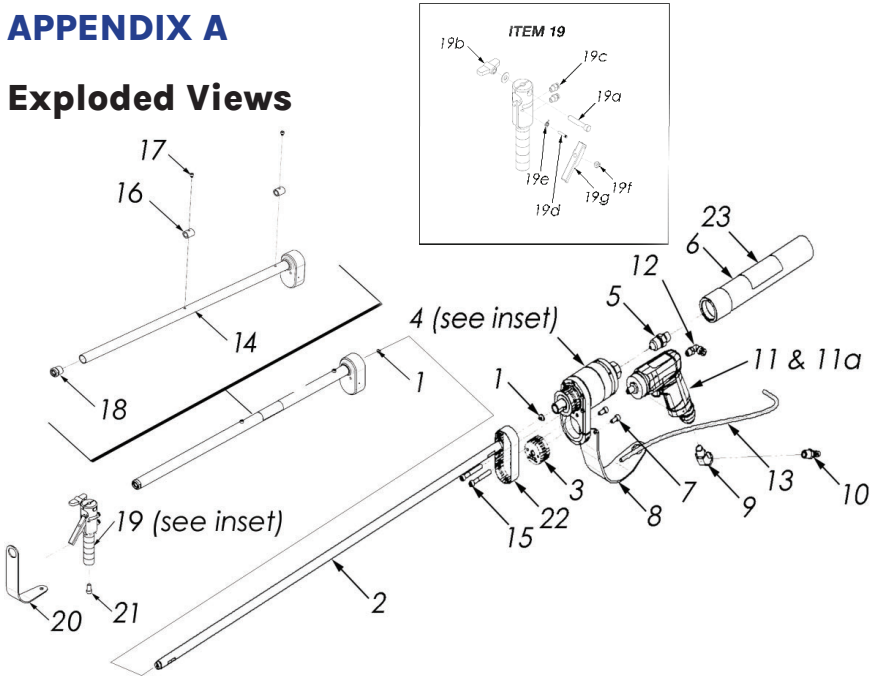

Figure B

Assembly PNs 66210, 66211							
Item	Qty	Part Number	Description	Item	Qty	Part Number	Description
1	2	54059	Button Seal	11a	1	66848	Drill Service Kit
2	1	53701	36" Barrel	12	1	27733	Elbow
		53894	48" Barrel	13	1	27740	Tubing
3	1	54307	Driver Sprocket	14	1	53790	36" Barrel Housing
4	1	66023	Swivel Assy			53895	48" Barrel Housing
4a	1	64123	Swivel Nut	15	2	27717	Capscrew
4b	1	53709	Inlet Adapter	16	1	53771	Center Barrel Bushing
4c	1	66021	Seal Kit	17	1	67325	Capscrew
4d	1	66022	Swivel Rebuild Kit	18	1	53972 (with seal)	Front Barrel Bushing
4e	1	27277	Pin	18a	1	27707	Barrel Seal
4f	6	27716	Capscrew	18b	1	53732	Front Barrel Bushing
4g	1	27713	Capscrew	19	1	67330	Secondary Handle
4h	1	53703	Mounting Plate	19a	1	53762	Clamp Stud
4j	1	27708	Shaft Seal	19b	1	64451	Nut
4k	1	53782	Driven Sprocket	19c	2	61678	Tubing Adapter
4m	1	27712	Retaining Ring	19d	1	53787	Pin
5	1	27530	Connector M9 x .38	19e	1	53798	Spring
6	1	53723	Hose Support	19f	1	61676	Valve
7	2	25261	Capscrew	19g	1	61670	Trigger
8	1	29808	Trigger Guard	20	1	27662	Trigger Guard
9	1	28224	Elbow	21	1	27714	Capscrew
10	1	28223	Male QD Fitting	22	1	27661	Belt
11	1	65098	Pneumatic Drill	23	2	64268	Label, VSS

**NOTE:** Part numbers and descriptions are subject to change without notice.

## APPENDIX B

### Accessories

#### Tornado Surface Cleaning FX Nozzle Heads

3, 4, 5, or 6 jet stainless steel nozzle heads for use with the FXG2 Tornado Spinner Gun. Button seal connection prevents wear and leakage of the nozzle.

PART NO.	DESCRIPTION
53970	F3-Jet Pattern
53971	F4-Jet Pattern
64448	F5-Jet Pattern
64449	F6-Jet Pattern
67434	F4-Narrow Jet Pattern (small diameter Head OD = 1.12")



#### Nozzle Shields and Retainers

Each nozzle head assembly comes with one nozzle shield.

PART NO.	DESCRIPTION
68006	2 Jet Nozzles
53763-SS	3 or 6 Jet Nozzles
64184-SS	4 Jet Nozzles
64013-SS	5 Jet Nozzles



**Part No. 27722** Capscrew (for 53763-SS, 64013-SS)

**Part No. 63860** Retaining Ring (for 68006, 64184-SS)

#### Nozzle Holder Guard (PN 64450)

Protects the nozzle head and barrel from wear and damage when using the air gun.



#### Front Bushing Guard (PN 66343)

Protects front bushing from wear and damage when using the air gun.



## Adjustable Shoulder Stocks (PN 66354 - Straight, PN 66930 - Offset)

Adjustable shoulder stocks are available for flexibility and comfort when using the air gun.



## UHPX/UHPXi/UHPXD Nozzles



**UHPX / UHPXD**



**UHPXi**

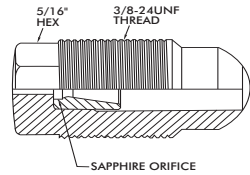

- Premier high productivity sapphire (UHPX and UHPXi) and synthetic diamond (UHPXD) nozzles with 3/8-24 threads.
- UHPX and UHPXD have 5/16" external hex, UHPXi have 5/32" internal hex
- Tapered orifice retainer reduces turbulence and provides a cohesive, aggressive waterjet.

## Spanner Wrench for Drive Sprocket (PN 63789)



## Air Drill Service Kit (PN 66848)



# APPENDIX C

## Flow Charts

### UHPX/UHPXi/UHPXD NOZZLES

UHPX PART NO.	UHPXi PART NO.	UHPXD PART NO.	ORIFICE SIZE*		30,000 PSI (2,069 BAR)		35,000 PSI (2,414 BAR)		40,000 PSI (2,758 BAR)	
			in	mm	gpm	lpm	gpm	lpm	gpm	lpm
UHPX-PLUG			NOT APPLICABLE							
UHPX-005	UHPXi-005	UHPXD-005	0.005	0.13	0.09	0.33	0.09	0.35	0.10	0.38
UHPX-006	UHPXi-006	UHPXD-006	0.006	0.15	0.12	0.47	0.13	0.51	0.14	0.55
UHPX-007	UHPXi-007	UHPXD-007	0.007	0.18	0.17	0.64	0.18	0.69	0.20	0.74
UHPX-008	UHPXi-008	UHPXD-008	0.008	0.20	0.22	0.84	0.24	0.91	0.26	1.0
UHPX-009	UHPXi-009	UHPXD-009	0.009	0.23	0.28	1.1	0.30	1.1	0.32	1.2
UHPX-010	UHPXi-010	UHPXD-010	0.010	0.25	0.35	1.3	0.37	1.4	0.40	1.5
UHPX-011	UHPXi-011	UHPXD-011	0.011	0.28	0.42	1.6	0.45	1.7	0.48	1.8
UHPX-012	UHPXi-012	UHPXD-012	0.012	0.30	0.50	1.9	0.54	2.0	0.58	2.2
UHPX-013	UHPXi-013	UHPXD-013	0.013	0.33	0.59	2.2	0.63	2.4	0.68	2.6
UHPX-014	UHPXi-014	UHPXD-014	0.014	0.36	0.68	2.6	0.73	2.8	0.78	3.0
UHPX-015	UHPXi-015	UHPXD-015	0.015	0.38	0.78	3.0	0.80	3.2	0.90	3.4
UHPX-016	UHPXi-016	UHPXD-016	0.016	0.41	0.89	3.4	1.0	3.6	1.0	3.9
UHPX-017	UHPXi-017	UHPXD-017	0.017	0.43	1.0	3.8	1.1	4.1	1.2	4.4
UHPX-018	UHPXi-018	UHPXD-018	0.018	0.46	1.1	4.2	1.2	4.6	1.3	4.9
UHPX-019	UHPXi-019	UHPXD-019	0.019	0.48	1.3	4.7	1.4	5.1	1.4	5.5
UHPX-020	UHPXi-020	UHPXD-020	0.020	0.51	1.4	5.2	1.5	5.7	1.6	6.1
UHPX-021	UHPXi-021	UHPXD-021	0.021	0.53	1.5	5.8	1.7	6.2	1.8	6.7
UHPX-022	UHPXi-022	UHPXD-022	0.022	0.56	1.7	6.3	1.8	6.9	1.9	7.3
UHPX-023	UHPXi-023	UHPXD-023	0.023	0.58	1.8	6.9	2.0	7.5	2.1	8.0
UHPX-024	UHPXi-024	UHPXD-024	0.024	0.61	2.0	7.3	2.2	8.2	2.3	8.7
UHPX-025	UHPXi-025	UHPXD-025	0.025	0.64	2.2	8.2	2.3	8.9	2.5	9.5
UHPX-026	UHPXi-026	UHPXD-026	0.026	0.66	2.3	8.9	2.5	9.6	2.7	10.2
UHPX-027	UHPXi-027	UHPXD-027	0.027	0.68	2.5	9.6	2.7	10.3	2.9	11.0
UHPX-028	UHPXi-028	UHPXD-028	0.028	0.71	2.7	10.3	2.9	11.1	3.1	11.9
UHPX-029	UHPXi-029	UHPXD-029	0.029	0.73	2.9	11.0	3.2	11.9	3.4	12.7
UHPX-030	UHPXi-030	UHPXD-030	0.030	0.76	3.1	11.8	3.4	12.8	3.6	13.6
UHPX-031	UHPXi-031	UHPXD-031	0.031	0.78	3.3	12.6	3.6	13.6	3.8	14.6
UHPX-032	UHPXi-032	UHPXD-032	0.032	0.81	3.6	13.4	3.8	14.5	4.1	15.5
UHPX-033	UHPXi-033	UHPXD-033	0.033	0.83	3.8	14.3	4.1	15.4	4.4	16.5

\* Orifice size is denoted in the part number (-018, etc.).

Flow rate in chart is per nozzle. Multiply flow by the number of nozzles being used to determine the overall flow rate of the tool

# UHPX/UHPXi/UHPXD NOZZLES

UHPX PART NO.	UHPXi PART NO.	UHPXD PART NO.	ORIFICE SIZE*		30,000 PSI (2,069 BAR)		35,000 PSI (2,414 BAR)		40,000 PSI (2,758 BAR)	
			in	mm	gpm	lpm	gpm	lpm	gpm	lpm
UHPX-034	UHPXi-034	UHPXD-034	0.034	0.86	4.0	15.2	4.3	16.4	4.6	17.5
UHPX-035	UHPXi-035	UHPXD-035	0.035	0.89	4.2	16.1	4.6	17.4	4.9	18.6
UHPX-036	UHPXi-036	UHPXD-036	0.036	0.91	4.5	17.0	4.9	18.4	5.2	19.6
UHPX-037	UHPXi-037	UHPXD-037	0.037	0.93	4.7	18.0	5.1	19.4	5.5	20.7
UHPX-038	UHPXi-038	UHPXD-038	0.038	0.96	5.0	18.9	5.4	20.5	5.8	21.9
UHPX-039	UHPXi-039	UHPXD-039	0.039	0.99	5.3	19.9	5.7	21.5	6.1	23.0
UHPX-040	UHPXi-040	UHPXD-040	0.040	1.02	5.5	21.0	6.0	22.7	6.4	24.2
UHPX-042	UHPXi-042	UHPXD-042	0.042	1.06	6.1	23.1	6.6	25.0	7.1	26.7
UHPX-046	UHPXi-046	UHPXD-046	0.046	1.16	7.3	27.7	7.9	30.0	8.5	32.0
UHPX-052	UHPXi-052	UHPXD-052	0.052	1.32	9.4	35.5	10.1	38.3	10.8	40.9
UHPX-067	UHPXi-067	UHPXD-067	0.067	1.70	15.6	58.9	16.8	63.6	18.0	68.0

\* Orifice size is denoted in the part number (-018, etc.).

Flow rate in chart is per nozzle. Multiply flow by the number of nozzles being used to determine the overall flow rate of the tool

## WARRANTY

**Limited Warranty.** Each Waterblast Unit, Bareshaft Pump, and Fluid End manufactured by Jetstream is warranted against defects in material and workmanship for a period of 12 months or 1,000 hours, provided it is used in a normal and reasonable manner and in accordance with all operating instructions. If sold to an end user, the applicable warranty period commences from the date of delivery to the end user. If used for rental purposes, the applicable warranty period commences from the date of delivery to the party holding the equipment available for rent. This limited warranty may be enforced by any subsequent transferee during the warranty period. This limited warranty is the sole and exclusive warranty given by Jetstream.

**Exclusive Remedy.** Should any warranted product fail during the warranty period, Jetstream will cause to be repaired or replaced, as Jetstream may elect, any part or parts of such Waterblast Unit, Bareshaft Pump, or Fluid End that the examination discloses in Jetstream's sole judgment to be defective in material or factory workmanship. Repairs or replacements are to be made at Jetstream in Houston, Jetstream FS Solutions Rental Center, the customer's location, or at other locations approved by Jetstream. Labor is furnished only when the unit or part is returned to the factory or when travel and expenses are paid by the purchaser. Freight, travel and expenses incurred in connection with repair or warranty are excluded from this warranty and shall be paid by the purchaser. The foregoing remedies shall be the sole and exclusive remedies of any party making a valid warranty claim.

The Jetstream Limited Warranty shall NOT apply to (and Jetstream shall NOT be responsible for):

1. Major components or trade accessories that have a separate warranty from their original manufacturer, such as, but not limited to: diesel engines, electric motors, electronic soft starter and/or across the line starter panels, axles, PTO's, clutch packs, high pressure gauges, high pressure hoses, flex lances, etc.
2. Normal adjustments and maintenance services.
3. Normal wear parts such as, but not limited to: oil, clutches, belts, filters, packing, cartridges, univalves, face seals, diffusers, gland nut bushings, plungers, nozzles, rupture disks, etc.
4. Failures resulting from the machine being operated in a

manner or for a purpose not recommended by Jetstream including failures or malfunctions resulting from corrosion, misapplication, overpressurization, inadequate pump suction conditions, improper water quality, improper maintenance, or misuse.

5. Repairs, modifications or alterations which in Jetstream's sole judgment, have adversely affected the machine's stability, operation or reliability as originally designed and manufactured.

6. Items subject to misuse, negligence, accident or improper maintenance.

\*NOTE\* The use of any part other than ones approved by Jetstream may invalidate this warranty. Jetstream reserves the right to determine, in its sole discretion, if the use of non-approved parts invalidates the warranty. Nothing contained in this warranty shall make Jetstream liable for loss, injury, or damage of any kind to any person or entity resulting from any defect or failure in the machine or part.

THIS WARRANTY IS, AND SHALL BE IN LIEU OF ALL OTHER WARRANTIES, EXPRESS OR IMPLIED, INCLUDING WITHOUT LIMITATION, ANY IMPLIED WARRANTIES OF MERCHANTABILITY OR FITNESS FOR A PARTICULAR PURPOSE, ALL OF WHICH ARE DISCLAIMED. THIS DISCLAIMER AND EXCLUSION SHALL APPLY EVEN IF ANY WARRANTY POSSIBLY ASSERTED FAILS OF ITS ESSENTIAL PURPOSE.

This warranty is in lieu of all other obligations or liabilities, contractual and otherwise, on the part of Jetstream. For the avoidance of doubt, Jetstream shall not be liable for any indirect, special, incidental or consequential damages, including, but not limited to, loss of use or lost profits. Jetstream makes no representation that the unit has the capacity to perform any functions other than as contained in Jetstream's written literature, catalogs or specifications accompanying delivery of the machine. No person or affiliated company representative is authorized to alter the terms of this warranty, to give any other warranties or to assume any other liability on behalf of Jetstream in connection with the sale, servicing or repair of any machine manufactured by Jetstream. Any legal action based hereon must be commenced within eighteen (18) months of the event or facts giving rise to such action.

Jetstream reserves the right to make design changes or improvements in its products without imposing any obligation upon itself to change or improve previously manufactured products.

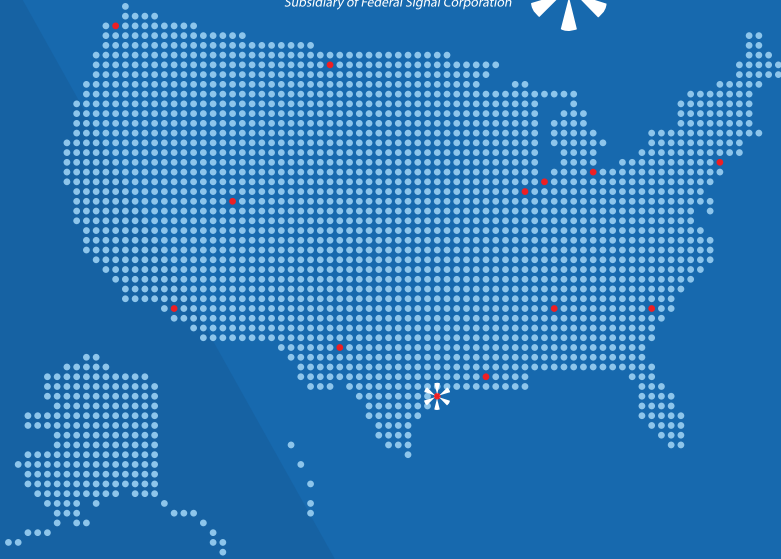

Jetstream products are also serviced by FS Solutions. With 13 convenient locations across the United States, FS Solutions provides high-performance parts, accessories, Jetstream rentals, repair, rebuild and safety training.



**FS Solutions™**

Gonzales, LA  
(225) 647-0660

Highland, IN  
(219) 924-3180

Lakewood, WA  
(253) 584-0653

Toledo, OH  
(888) 415-7368

LaPorte, TX  
(281) 674-8668

Streator, IL  
(815) 672-6028

Williston, ND  
(701) 572-7421

Lexington, SC  
(803) 996-0741

Leeds, AL  
(800) 822-8785

Long Beach, CA  
(866) 515-9891

New Brunswick, NJ  
(732) 448-7830

Midland, TX  
(432) 563-4450

Salt Lake City, UT  
(801) 808-4590

## **JETSTREAM OF HOUSTON**

5905 THOMAS ROAD  
HOUSTON, TEXAS 77041  
(832) 590-1300 or (800) 231-8192

[SALES@WATERBLAST.COM](mailto:SALES@WATERBLAST.COM) | [WATERBLAST.COM](http://WATERBLAST.COM)

### **Application Policy**

Capacity ratings, features, and specifications vary depending upon the model and type of service. Application approvals must be obtained from Jetstream; contact your representative for application approval. We reserve the right to change or modify our product specifications, configurations, or dimensions at any time without notice.