

**INTEGRATED TRAILER**

# 52000 UNIT

**ARTICULATING CONTROL PANEL MOUNT (OPTIONAL)**

Positionable control panel for easy access either from ground or on trailer deck.

**TRANSMISSION DRIVE**

4-speed transmission and integrated pump gear drive for efficient performance

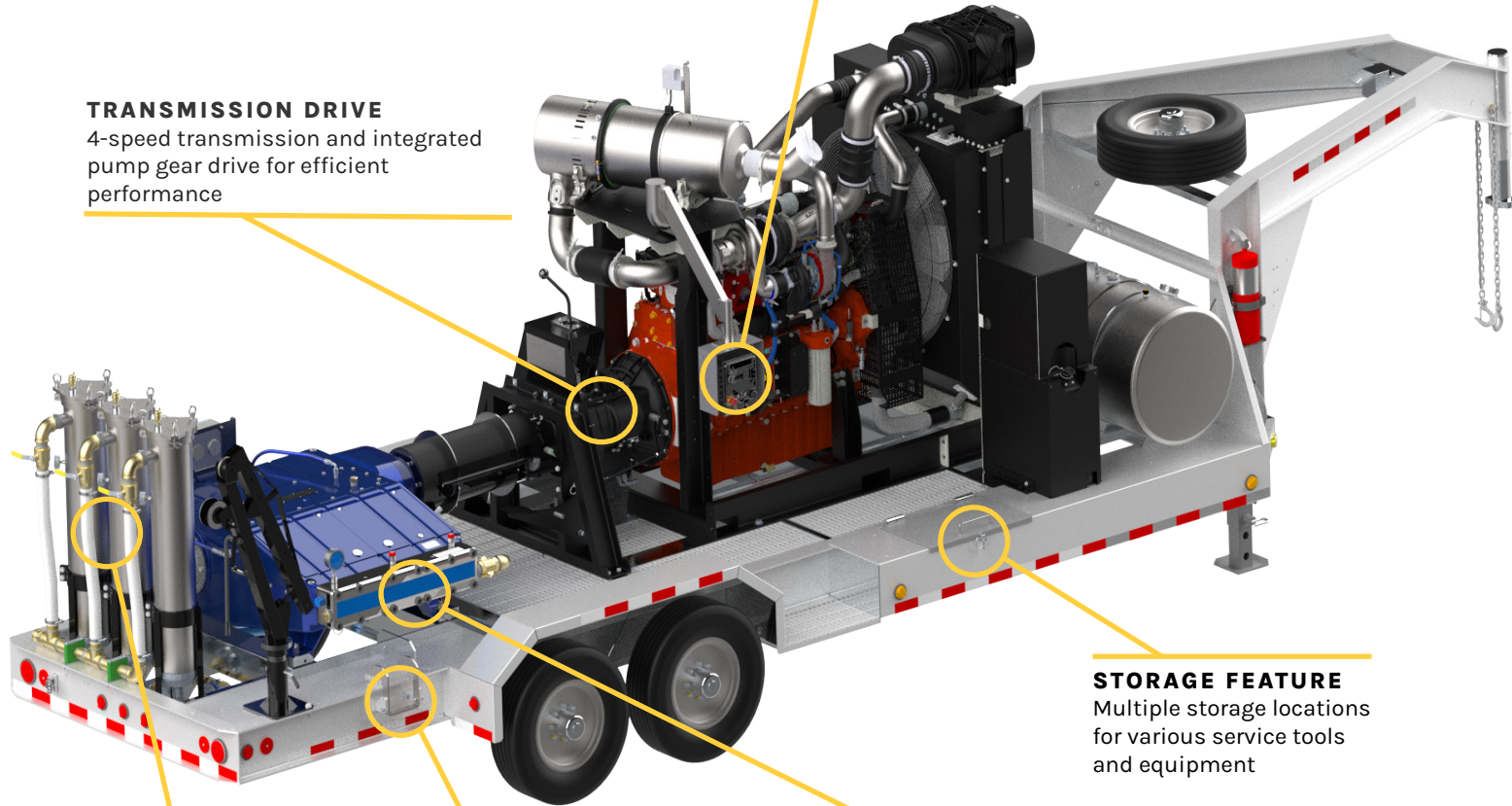

**STORAGE FEATURE**

Multiple storage locations for various service tools and equipment

**GUARDIAN TRIPLE FILTRATION SYSTEM**

Three filters allows the pump to continue operating while changing filters without shutting the unit down

**INTEGRATED STEP**

Low deck integrated gooseneck trailer with storage, steps and crane.

**QUINTUPLEX DESIGN & UNx FLUID END TECHNOLOGY**

Five plungers reduce pulsation for powerful high flow operation. Quick in-the-field valve changes decrease downtime

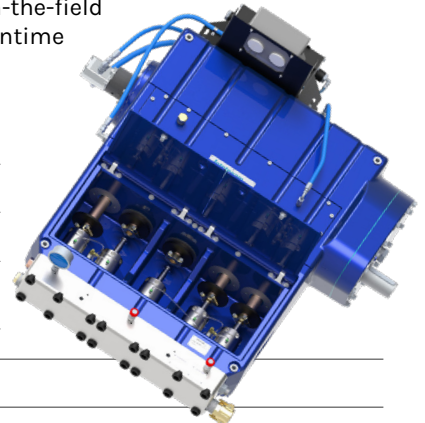

**QUINTUPLEX DESIGN**

<b>MAX. POWER</b>	700HP (522 KW)
<b>MAX. FLOW</b>	136.2 GPM (516 LPM) AT 8,000 PSI (551 BAR)
<b>DIMENSIONS L X W X H (TRAILER DIMENSIONS)</b>	355" X 102" X 110" (DECK HEIGHT 28")

**POWER SPECS**

**MAX FRAME LOAD** 17,716LB (79KN)

STROKE		FLUID END CONNECTION TYPE	PUMP SPEED RANGE	MAX. POWER INPUT		GVWR		PUMP OIL		
in	mm			hp	kw	lb	kg	TYPE	CAPACITY	
			RPM					gal	l	
5.25	133	DISCHARGE 15K: Jetstream HF 20K: Jetstream HHP 40K: Jetstream 40K	200-547	700	522	20,000	9661.5	80W-90	27	102



## FLUID END SPECS

INPUT RPM	PLUNGER SIZE NO.	MAX PUMP DISPLACEMENT		MAX OPERATING PRESSURE	
		gpm	lpm	psi	bar
<b>MODEL 5240Q</b>					
700HP					
1800	#8	26.0	98	40,000	2750
<b>MODEL 5220Q</b>					
700HP					
1800	#11	55.1	208	20,000	1379
2100	#11	54.2	205		
600HP					
1800	#11	46.4	176	20,000	1379
2100	#10	46.1	174		
<b>MODEL 5215Q</b>					
700HP					
1800	#12	70.3	266	15,000	1035
	#13	87.0	329	12,500	863
	#15	109.8	416	10,000	690
2100	#12	69.2	262	15,000	1035
	#13	85.6	324	12,500	863
	#15	108.1	409	10,000	690
600HP					
1800	#12	59.3	224	15,000	1035
	#13	73.4	277	12,500	863
	#15	92.6	350	10,000	690

\*\*Flow values represented refer to "theoretical" flow, neglecting inefficiency resulting from compressibility of water and expansion of pressure bearing components. Actual values may vary depending on the engine used to power the pump.



SEE IT IN ACTION  
**INTEGRATED TRAILER**  
**5200Q**



## OUR REACH



Jetstream Parts, Accessories and Rentals are also available through FS Solutions, with 13 convenient U.S. locations

**Gonzales, LA**  
(225) 647-0660

**Highland, IN**  
(219) 924-3180

**Lakewood, WA**  
(253) 584-0653

**Toledo, OH**  
(888) 415-7368

**LaPorte, TX**  
(281) 674-8668

**Streator, IL**  
(815) 672-6028

**Williston, ND**  
(701) 572-7421

**Lexington, SC**  
(803) 996-0741

**Leeds, AL**  
(800) 822-8785

**Long Beach, CA**  
(866) 515-9891

**New Brunswick, NJ**  
(732) 448-7830

**Midland, TX**  
(432) 563-4450

**Salt Lake City, UT**  
(801) 808-4590



800.231.8192  
sales@waterblast.com



www.waterblast.com



5905 Thomas Road  
Houston, TX 77041